

High productivity for
cylindrical surfaces



BAR PEELING
tools solutions



SINCE 1916

BAR PEELING



BAR PEELING

Bar Peeling is the machining process by which a raw forged blank is converted into a polished bar.

During this peeling process, surface cracks and oxide layers are removed giving a perfect roundness with good surface and dimensional accuracy to the bar.

The range of materials that can be machined with these tools is vast and goes from all kind of Steels to Cast Iron parts.

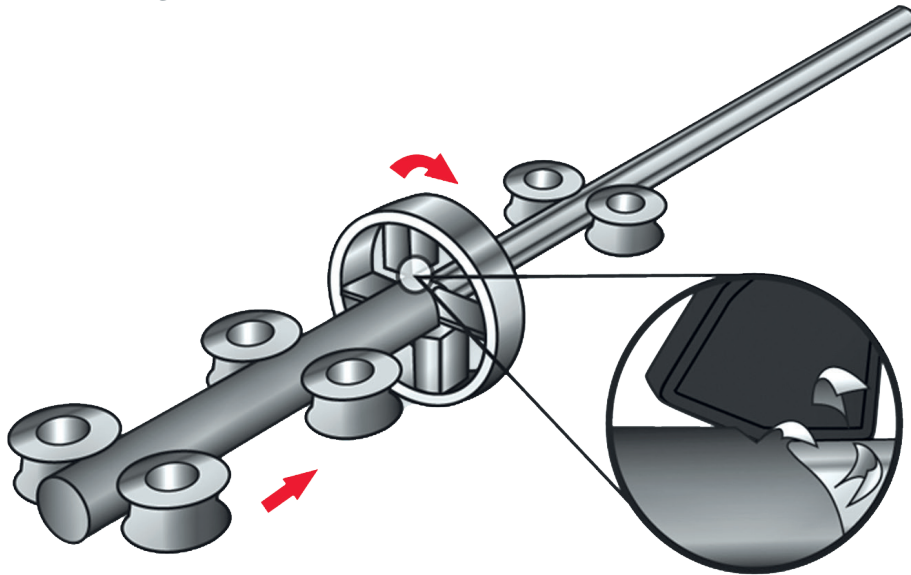

The size of blank bar can go from 4 mm (157 inch) to over 400 mm (15.75 inch) in diameter.

The surface quality and dimensional tolerances are also high, which leads to less machining at later stages.

Our aim is at the same time improving your productivity (by removing maximal chips volume) and at the same time attending or surpassing your surface quality requirements. This is why our Bar Peeling program is vast comprising both standard tools and also special custom-made solutions to every customer needs.

This flyer has only a small portion of our possible range of production. Please don't hesitate to contact us regarding other possible geometries that we may have although not presented in this brochure.

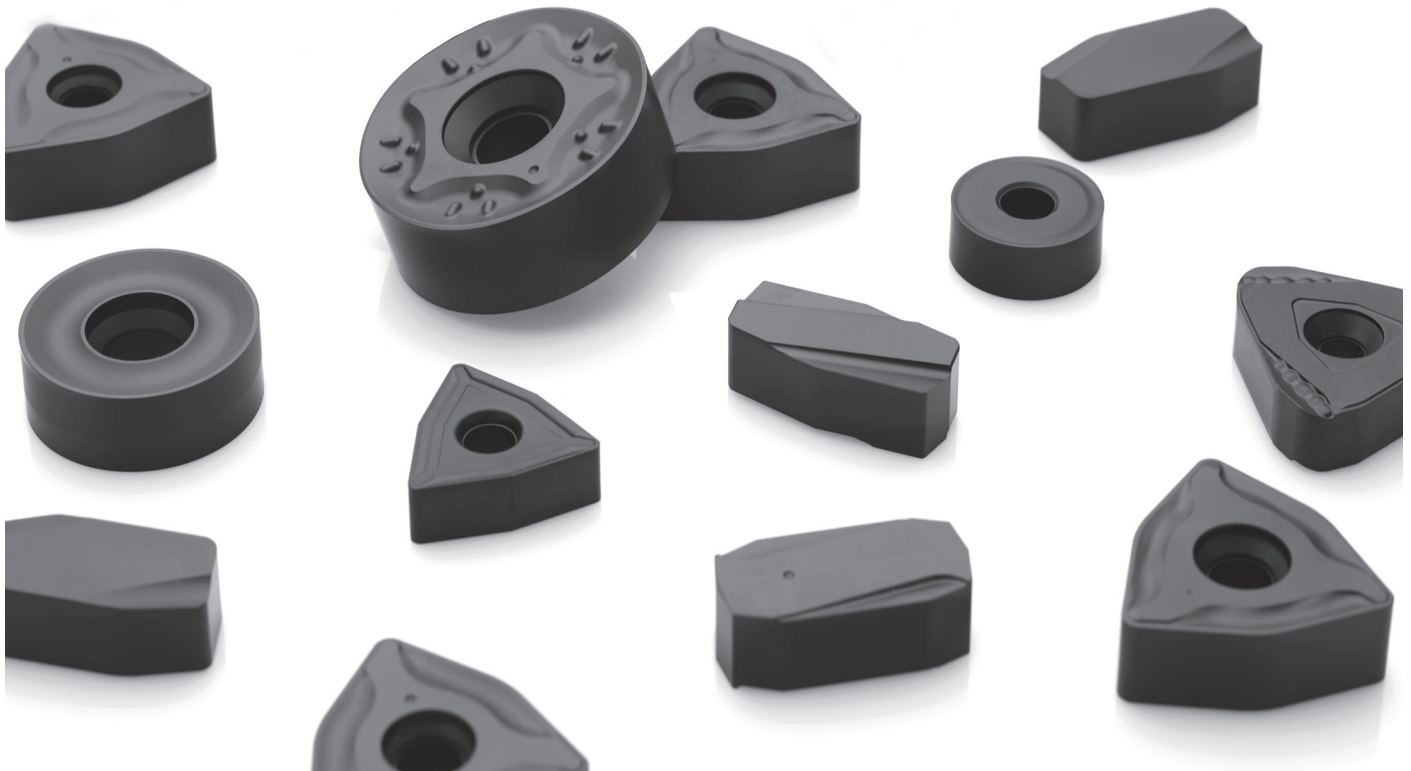

CODE KEY

L	N	G	F	20	10	35	-	MP
1	2	3	4	5	6	7		8

1 - Insert Shape				
I	J	L	R	S
60°		75° / 80°	85° / 90°	
T	U	W	X	

2 - Clearance Angle
N

5 - Length of Cutting Edge (In)	
The length of the secondary cutting edge is indicated in mm	
13 mm	25 mm
14 mm	27 mm
15 mm	28 mm
17 mm	38 mm
20 mm	44 mm
22 mm	50 mm

3 - Tolerances			
symbol	m (mm)	d (mm)	s (mm)
A	±0.005	±0.025	±0.025
F	±0.005	±0.013	±0.025
C	±0.013	±0.025	±0.025
H	±0.013	±0.013	±0.025
E	±0.025	±0.025	±0.025
G	±0.025	±0.025	±0.13
J	±0.005	±0.05~±0.13	±0.025
K*	±0.013	±0.05~±0.13	±0.025
L*	±0.025	±0.05~±0.13	±0.025
M*	±0.08~±0.20	±0.05~±0.13	±0.13
N*	±0.08~±0.20	±0.05~±0.13	±0.025
U*	±0.13~±0.38	±0.08~0.25	±0.13

* As a rule, the sides of these inserts are as sintered.
Tolerance differs with insert size, for the accuracy of Class M, refer to the table on the right.

4 - Insert type				
symbol	Type	Type of hole	Chipbreaker	Shape
W	with hole	Round hole / one countersink (40°~60°)	Without chipbreaker	
T	with hole		Chipbreaker on one side	
Q	with hole	Round hole / double countersink (40°~60°)	Without chipbreaker	
U	with hole		Chipbreaker on both sides	
B	with hole	Round hole / double countersink (70°~90°)	Without chipbreaker	
H	with hole		Chipbreaker on one side	
C	with hole		Without chipbreaker	
J	with hole		Chipbreaker on both sides	
A	with hole	Round hole	Without chipbreaker	
M	with hole		Chipbreaker on one side	
G	with hole		Chipbreaker on both sides	
N	without hole	--	Without chipbreaker	
R	without hole	--	Chipbreaker on one side	
F	without hole	--	Chipbreaker on both sides	
X	-	-	--	On request









6 - Thickness (S)
The length of the secondary cutting edge is indicated in mm
08 = 8,00 mm
09 = 9,52 mm
10 = 10,00 mm
12 = 12,00 mm
12 = 12,70 mm
13 = 13,00 mm
14 = 14,00 mm
18 = 18,00 mm

8 - Chip Breaker	
Chip breaker according to Palbit geometries	
FP	MH
ST	RP
MP	LH

7 - Depth of Cut (ap)
Maximum depth of cut
20 = 2,00 mm
25 = 2,50 mm
35 = 3,50 mm
40 = 4,00 mm
80 = 8,00 mm

BAR PEELING INSERTS RANGE

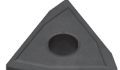
NEGATIVE INSERTS | PASTILHAS NEGATIVAS | PLAQUITAS NEGATIVAS

	⁽¹⁾ Geometry code	⁽²⁾ Grade code ANSI ISO Reference	P										M						K		Cutting conditions Condições de corte Condiciones de Corte													
			L7	R2	L8	R3	U5	P1	V8	N2	S9	L9	U4	L8	U5	N2	P1	V8	V6	L5	L6	L9	ap (mm)	Min	Max	fn (mm/r)	Min	Max						
			PH5115	PHG115	PH5125	PHG125	PHS225	PHS228	PHS228	PH5135	PHG135	PH5740	PHS215	PHS125	PHS225	PHS135	PHS228	PHS228	PHS240	PHS705	PHS320	PHS740												
 INGR-MP Rectangular 90°	1123828	INGR 221240-MP	⊗	○	○																○							2,00	0,40	4,00	3,50	1,00	8,00	
	1123830	JNGF 201220-MP	○	⊗	○					○		⊗										⊗							1,50	1,00	2,00	3,50	1,50	6,00
 JNGF-MP Rectangular 90°	1123996	JNGF 201220-MP SP1		○																	○							1,50	1,00	2,00	3,50	1,50	6,00	
	1123997	JNGF 201220-MP SP2	⊗	⊗								⊗								○		⊗							1,50	1,00	2,00	3,50	1,50	6,00
	1124043	JNGF 271220-MP		⊗						○		⊗									○		⊗							1,50	1,00	2,00	3,50	1,50
 JNGF-PM Rectangular 90°	1124452	JNGF 201220-PM		○								⊗										⊗							1,50	1,00	2,00	4,00	2,00	6,00
	1124567	JNGF 201220-PM SP		○																										1,50	1,00	2,00	4,00	2,00
 LNGF-MP Rectangular 90°	1123826	LNGF 201035-MP	○	⊗	○			○						○						⊗		○							2,00	0,80	3,50	2,50	1,00	6,50
	1123827	LNGF 201235-MP	○	○	○									○									○							2,00	0,80	3,50	2,50	1,00
 UNGF-MP Rectangular 90°	1123829	UNGF 171240-MP	○		○	⊗								○								○							1,50	0,35	4,00	2,00	1,00	5,00
 TNMJ-MP Triangular 60°	1123838	TNMJ 201025-MP	⊗	⊗	⊗	⊗	⊗							⊗	⊗							⊗							1,00	0,70	2,50	3,00	1,00	5,50
	1123843	TNMJ 201425-MP		⊗	○									⊗									⊗							1,00	0,70	2,50	3,00	1,00
 TNGM-MP Triangular 60°	1124104	TNGM 220812-MP		⊗						⊗	⊗			⊗	⊗							⊗							0,70	0,20	1,30	14,00	5,00	18,00
 TNMM-LH Triangular 60°	1124102	TNMM 441116-LH								○	⊗			○															12,00	2,00	25,00	0,80	0,50	1,60

⊗ First choice | 1ª Escolha | 1ª Opción

⊗ Stock items | Itens de stock

⊗ Stock available until sold out | Stock disponível até acabar o stock | Stock disponible hasta acabar el stock





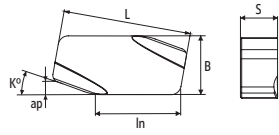
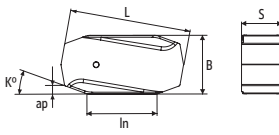
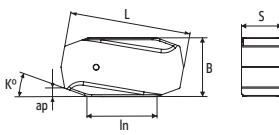
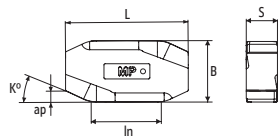
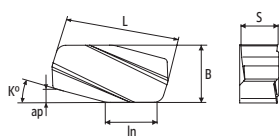
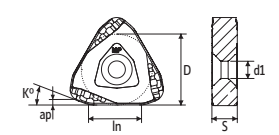
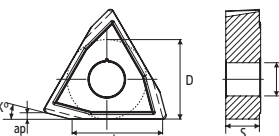
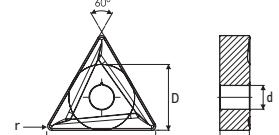

○ Available under request | Disponível sob consulta | Disponible bajo consulta

Insert Order Code: ⁽¹⁾Geometry code + ⁽²⁾Grade code

Dimensions Dimensões Dimensions (mm)									Technical Drawing Desenho Técnico Diseño Técnico
L	D	ln	B	S	d1	r	ap	K°	
38,25	-	22,00	17,50	12,00	-	-	4,00	20	
36,90	-	20,00	18,00	12,35	-	-	2,00	20	
36,30	-	20,00	18,00	12,45	-	-	2,00	20	
36,50	-	20,00	18,00	12,45	-	-	2,00	20	
36,90	-	27,00	18,00	12,45	-	-	2,00	20	
37,52	-	21,00	18,00	12,45	-	-	3,00	20	
37,52	-	21,00	18,00	12,45	-	-	3,00	20	
40,00	-	20,00	20,00	10,00	-	-	3,50	25	
40,00	-	20,00	20,00	12,00	-	-	3,50	25	
36,50	-	17,00	18,00	12,00	-	-	4,00	15	
-	28,60	20,00	-	10,00	7,00	-	2,50	20	
-	28,60	20,00	-	14,00	7,00	-	2,50	20	
-	19,05	22,00	-	8,00	7,96	-	1,20	15	
-	25,40	11,50	-	25,40	44,00	1,60	-	-	

BAR PEELING INSERTS RANGE

NEGATIVE INSERTS | PASTILHAS NEGATIVAS | PLAQUITAS NEGATIVAS

	(1) Geometry code	(2) Grade code ANSI ISO Reference	P									M						K	Cutting conditions Condições de corte Condiciones de Corte									
			L7	R2	L8	R3	U5	P1	V8	N2	S9	L9	U4	L8	U5	N2	P1	V8	V6	L5	L6	L9	ap (mm)	Min	Max	fn (mm/r)	Min	Max
 XNMJ-MP Special 85°	1123835	XNMJ 151380-MP	○	⊗			⊗	○					⊗	○	⊗								3,00	1,00	6,50	6,00	4,00	12,00
 XNMJ-MH Special 85°	1123836	XNMJ 151380-MH	○	○	⊗		⊗			○		⊗		⊗							○		3,00	1,00	6,50	6,00	4,00	12,00
 XNGF-FP Special 85°	1123837	XNGF 150980-FP			○				○			○	○	⊗									3,00	1,00	4,50	6,00	4,00	12,00
 XNGJ-RP Special 85°	1123834	XNGJ 151380-RP			○								○		⊗								3,00	1,00	6,50	6,00	4,00	12,00
 WNGJ-MP Special 75°	1124041	WNGJ 130950-MP			⊗	○		⊗					⊗		⊗				○	⊗			3,00	0,50	5,00	6,00	3,00	11,00
 RNMX-MP Round R°	1123831	RNMX 381200-MP	○	○	⊗		○					○		⊗	○								4,00	2,00	8,00	2,00	1,00	4,00
	1123832	RNMX 5018M0-MP	○	○			⊗					○		○	⊗									6,00	2,00	12,00	3,50	2,50
 RNMX-RP Round R°	1123833	RNMX 5018M0-RP	○	○			○					○		⊗	○								6,00	2,00	12,00	6,00	4,00	10,50

⊗ First choice | 1ª Escolha | 1ª Opción

⊗ Stock available until sold out | Stock disponível até acabar o stock | Stock disponible hasta acabar el stock

Insert Order Code: (1) Geometry code + (2) Grade code

⊗ Stock Items | Itens de stock

○ Available under request | Disponível sob consulta | Disponible bajo consulta

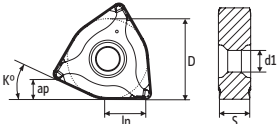
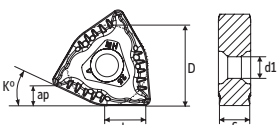
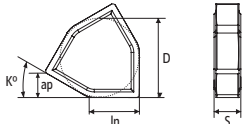
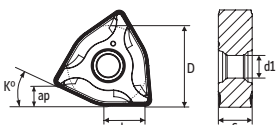
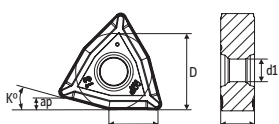
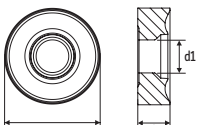
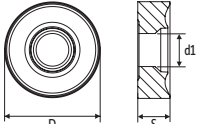
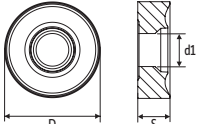
Dimensões Dimensões Dimensions (mm)									Technical Drawing Desenho Técnico Diseño Técnico
L	D	ln	B	S	d1	r	ap	K°	
-	31,75	15,00	-	13,00	9,00	-	8,00	25	
-	31,75	15,00	-	13,00	9,00	-	8,00	25	
-	28,58	15,00	-	8,88	-	-	8,00	30,00	
-	31,75	15,00	-	13,00	9,00	-	8,00	25	
-	22,23	13,00	-	9,56	7,93	-	5,00	15	
-	38,10	-	-	12,70	13,00	-	-	-	
-	50,00	-	-	18,00	12,70	-	-	-	
-	50,00	-	-	18,00	12,70	-	-	-	

BAR PEELING
tools solutions

HEADQUARTERS

PALBIT, S.A.

P.O.Box 4 - Palhal

3854-908 - Branca ALB - Portugal

T (+351) 234 540 300 | F (+351) 234 540 301

palbit@palbit.pt | www.palbit.pt

Branch office:

PALBIT México

Emerson 150. Int.803-804. Colonia Chapultepec

Morales Delagación Miguel Hidalgo

C.P. 11570 México DF

T (+52) 5555 454 543 | F (+52) 5552 509 190

info@palbit.com.mx | www.palbit.com.mx



* **RNMX-RP** | Product in real size

Produto em tamanho real

Producto en tamaño real

